

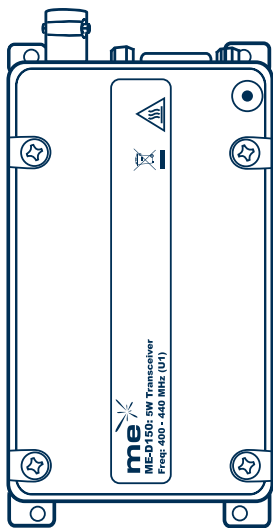

**me-d150 range**



**User Guide**



# 1 Contents

|           |  |           |
|-----------|--|-----------|
| <b>1</b>  | <b>Contents</b> .....                                | <b>1</b>  |
| <b>2</b>  | <b>Introduction</b> .....                            | <b>2</b>  |
| <b>3</b>  | <b>Preparing for use</b> .....                       | <b>3</b>  |
| 3.1       | Unpacking and inspection.....                        | 3         |
| 3.2       | Description of modem.....                            | 4         |
| 3.3       | Features.....  | 4         |
| 3.4       | External Connections.....                            | 5         |
| 3.5       | PIN Outs .....                                       | 6         |
| 3.6       | DB-9 PIN OUT table with input and output levels..... | 6         |
| <b>4</b>  | <b>Operation</b> .....                               | <b>8</b>  |
| 4.1       | Channel Selection.....                               | 8         |
| 4.2       | Transmit/Receive Operation .....                     | 9         |
| 4.3       | Serial Commands .....                                | 9         |
| 4.4       | Transmit command and data (To D150) .....            | 10        |
| 4.5       | Receive Command and data (response from D150).....   | 10        |
| 4.6       | Status indicators .....                              | 11        |
| <b>5</b>  | <b>Programming</b> .....                             | <b>12</b> |
| <b>6</b>  | <b>Installation</b> .....                            | <b>13</b> |
| 6.1       | Antennas.....  | 13        |
| 6.2       | Power sources .....                                  | 13        |
| 6.3       | Cabling.....   | 13        |
| 6.4       | Fixing .....   | 14        |
| <b>7</b>  | <b>Safety and general information</b> .....          | <b>15</b> |
| 7.1       | Exposure to radio frequency energy.....              | 15        |
| 7.2       | Electromagnetic interference/compatibility .....     | 15        |
| 7.3       | Medical devices (Pacemakers).....                    | 15        |
| 7.4       | Vehicles with airbags .....                          | 16        |
| 7.5       | Potentially explosive atmospheres .....              | 16        |
| <b>8</b>  | <b>Warranty and repairs</b> .....                    | <b>16</b> |
| <b>9</b>  | <b>Care of the equipment</b> .....                   | <b>17</b> |
| <b>10</b> | <b>Disposal / Recycling</b> .....                    | <b>17</b> |

## 2 Introduction

The D150 range is a 1 to 5 Watt PMR data modem at VHF and UHF frequencies

The D150 is housed in a rugged cast-aluminium box sealed to IEC 529 (IP54) making it suitable for a wide range of mobile and fixed applications.

The D150 modem is designed to meet international levels of safety and performance. To maintain this the installation and safety information must be adhered to.

- The D150 modem must only be installed where unintentional contact cannot be made. The surface of the device may be hot to touch under certain transmit conditions. The D150 is not designed for permanent transmission. If prolonged transmission periods are used, the unit will become hot and will require an additional heatsink to be fitted.
- When fitting the modem into a fixed installation, care must be taken in the routing of all cabling such that the insulation cannot become damaged.
- The recommended supply sources for use with the D150 are a standard 12V / 2A dc supply, but is capable of operating in the range 9V - 18V. It is recommended that suitable in-line fusing is added to the +ve (positive) line. See Sections 6 and 7 for further detail.

## 3 Preparing for use

### 3.1 Unpacking and inspection

Unpack the modem and check that you have received the following items:

- D150 modem
- User Guide (this document)

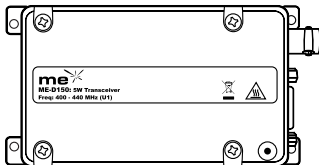

If any of these items are missing, please contact your supplier.

## 3.2 Description of modem

The D150 is a network free, point to point data radio that offers great flexibility in varied applications where wireless data or voice communication is needed.

It can be used as a transparent radio, with no internal modem fitted, to allow users to facilitate the use of their own modem and protocol. The correct signal levels need to be used with the use of separate control lines, see the pin out table below.

The D150 can also be fitted with a Bell 202/V23 modem\* (1200 baud rate). The internal modem allows communication with a pc using RS 232 for the data and control lines. For further details, please refer to the modem manual. (\*Due 2008)

D150 has standard radio features available which are associated with a private radio. This includes high and low power levels, CTCSS and DCS, software controlled squelch, time out timer options and busy channel lockout as listed below (not all available with option modem fitted). There is a microphone input and speaker output to allow speech to be transmitted and received.

## 3.3 Features

- Compact and rugged die cast box
- Resistant to dirt, dust and water ingress (IP54 rated)
- Network free, point to point communication
- 1/5 watt programmable output power
- Synthesised operation with 16 channel capability
- CTCSS/DCS when used with Bell 202/V23 modem or speech
- Programmable 12.5 / 25kHz channel spacing
- External modem / Direct FM
- Internal modem options available: Bell 202/V23
- 'Busy' output
- 9 – 18 volt supply input
- Busy Channel lockout
- Time out timer

### 3.4 External Connections

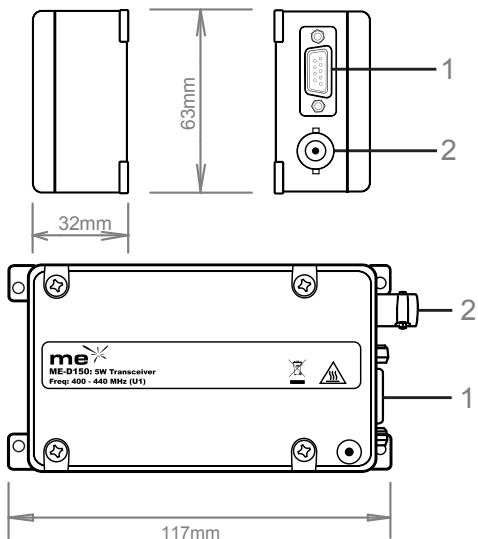

1. HD 9-way d-type (data, control signals and power supply)
2. BNC antenna connector

### 3.1 PIN Outs

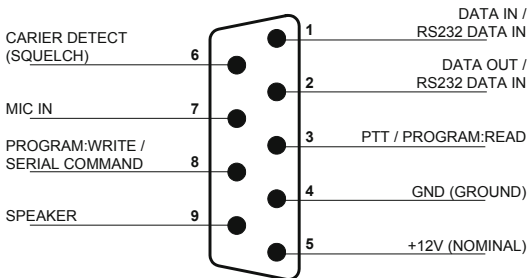

### 3.2 DB-9 PIN OUT table with input and output levels

| Pin No.       | Function                                     | Description   | Signal Type  | I/O |
|---------------|--|---|--|-----|
| 1 link option | Data modulation IN (used with an ext. modem) | A/c coupled signal directly injected to MOD through data low pass filter .<br>Link 409 fitted. Link 412 not fitted                              | Analogue signal<br>1KHz audio at 60% peak dev.<br>input level =100 to 120mVrms | I/P |
| 1 link option | RS 232 data IN                               | Input to Bell 202/V23 modem<br>Link 409 not fitted and link412 fitted   | RS232 level  | I/P |
| 2 link option | Data unfiltered OUT (RX disc)                | Discriminator audio from the D-200. Unprocessed AF signal (prior to tone filtering and de-emphasis)<br>Link 413 fitted and link 414 not fitted. | Analogue signal<br>1KHz audio at 60% peak dev.<br>produces 200 to 300mVrms     | O/P |
| 2 link option | RS 232 Data OUT                              | Output from Bell 202/V23 modem<br>Link 413 not fitted and link 414 fitted   | RS 232 levels  | O/P |

|   |  |  |   |     |
|---|--|--|---|-----|
| 3 | PTT In<br>(Tx Key) /<br>Program:<br>READ | Signal, which keys the transmitter (active low).<br>Note: If the option modem board is installed, the jumper board must select RS-232 signal levels. See Modem manual<br>Program : READ used for outputting programming data from mode | TTL level<br>0V = Tx<br>open cct = Rx<br><br>RS-232 level (option)<br>+12V = Tx<br>-12V = Rx<br><br>TTL level (RS 232 converter in cable) | I/P |
| 4 | Ground                                   | Ground connection to chassis of the radio.   | 0V (Chassis)  |     |
| 5 | +Ve                                      | Power connection:  | +12 Volts nominal<br>9v-18v extreme   | 1/P |
| 6 | Busy<br>(CD)                             | Logic level output to indicate presence of a carrier.<br>Note: If the option modem board is installed, the jumper board must select RS-232 signal levels. See Modem manual   | TTL level<br>0V = carrier<br>5V = no carrier<br>RS-232 level (option)<br>+12V = carrier<br>-12V = no carrier                              | O/P |
| 7 | MIC IN /<br>Monitor                      | Audio signal that is filtered (high pass and pre- emph) then follows same route as data mod through LPF. Sub-audio tone is mixed with audio after the LPF<br>Grounding line activates monitor action                                   | 1KHz audio at 60% peak system deviation<br>input level = 6 to 8Vrms<br><100 resistor to ground  | I/P |
| 8 | Program :<br>WRITE/<br>Serial<br>command | Used for inputting programming data and use of serial command  | TTL level (RS232 converter in cable)  | I/P |
| 9 | SPEAKER<br>OUT                           | Audio output from the audio amplifier.<br>Filtered by tone-filter and de-emphasis circuit.   | 1KHz audio at 60% peak dev. produces nominal 1Vrms @ 8Ω   | O/P |

## 4 Operation

### 4.1 Channel Selection

Channels are selected by the use of internal switches and can be set as shown below. The top 4 screws will need to be removed to gain access to the switches, care must be taken to avoid any damage which could invalidate the warranty. The channel can also be changed by a serial command inputted from the external control system.

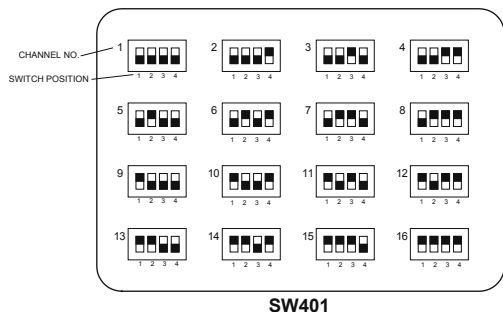

Figure: Setting of channel selector switch for each channel

## 4.2 Transmit/Receive Operation

The D150 is put into transmit/receive either by using TTL levels, RS 232 levels or serial command, depending on the application and modem set up.

When the radio is used with no internal modem, TTL levels (pin 3 on DB9) can be used. The default condition is active low for transmit, and active high, or not connected, for receive.

If an internal modem is fitted the levels used need to be RS232 and a jumper board needs to be incorporated in the correct position to allow correct operation, see modem manual.

The TX serial command (see later for further details) can also put the radio into transmit, until the rx serial command is received (pin 8 of DB9).

## 4.3 Serial Commands

The modem can be controlled by using the serial command (pin 8) , sending commands to the radio such as PTT or change channel

The format for these commands (asynchronous) are:

- baud rate: 4800 bit/sec
- Data Bit: 8 bit, non parity
- Stop Bit: 1 bit
- MSB first transmission

Each serial command consists of 3 bytes. The first byte is the command, the second is data required by the command and the third is the check sum to validate contents

Byte0

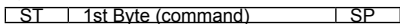

Byte1

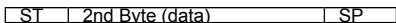

Byte2

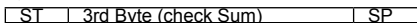

## 4.4 Transmit command and data (To D150)

|    | Mode            | Transmit command (byte0) | Transmit Data (byte1)                               | Check sum (byte2)<br>Transmit command + data |
|----|-----------------|--------------------------|---|--|
| 1. | Channel Change  | 0 x 64                   | 0x???: required channel                             | (0x64 + channel)                             |
| 2. | RTX Mode Send   | 0 x 61                   | R(0x72) : Rx mode<br>T(0x74) : Tx mode              | (0x61+0x72)<br>(0x61+0x74)                   |
| 3. | Modem test mode | 0x75                     | 0x78 : enable test data<br>0x79 : disable test data | (0x75 + 0x78)<br>(0x75 + 0x79)               |

\*?? = number of required channel

## 4.5 Receive Command and data (response from D150)

|    | Mode                      | Transmit Command (byte0) | Transmit data (byte1) | Check sum (byte2):<br>Transmit command + data |
|----|---------------------------|--------------------------|-----------------------|---|
| 1. | Process Complete commands | 0xaa                     | ACK                   |   |
|    |                           | 0x55                     | NACK                  |   |

If byte2 and the sum of byte0 and byte1 are the same, the D150 will send ACK (acknowledge) and execute command. If this is not the case, then the D150 sends NACK (not acknowledge). User would go into next step if receives ACK data. If user receives Nack data, user should send command again.

Example) To change from 1<sup>st</sup> Channel to 2<sup>nd</sup> Channel, the change command is: ( 0x64,0x02 , ( 0x64 + 0x2 )) to Radio. If Byte2 and sum of Byte0 and Byte1 among received data are same, radio sends ACK and changes to 2<sup>nd</sup> channel. If not, radio would send Nack data

## 4.6 Status indicators

The LED indicates the current status of the radio and if an external speaker is connected to pin 9 of the DB-9, audible tones can be heard under certain fault conditions. The details are shown below:

| Status               | Description                        | LED Colour          | Audible Tone     |
|----------------------|------------------------------------|---------------------|------------------|
| Normal               | Power On                           | Green-Orange-Red    |                  |
|                      | Busy Channel                       | Orange              |                  |
|                      | Correct Call (with SAT)            | Green               |                  |
|                      | Transmit                           | Red                 |                  |
|                      | Transmit Not Allowed               |                     |                  |
| Warning              | Busy Channel lockout               | Two Green flashes   | Single Beep Tone |
|                      | Time out Time                      | One Green flash     |                  |
|                      | Before 5S T-O-T                    | One Green flash     | Single Beep Tone |
|                      | EEPROM Error                       | One Orange flash    |                  |
|                      | Out of lock                        | Four Yellow flashes |                  |
|                      | Communication error with Modem MCU | Green LED flash     |                  |
|                      | Transmit Hang on time              | -                   | Single Beep Tone |
| Program              | Read Mode                          | Red LED flashes     |                  |
|                      | Write Mode                         | Green LED flashes   |                  |
| Squelch Program Mode | Initial data load                  | Green-orange-red    |                  |
|                      | Open Squelch Mode                  | Three Green flashes |                  |
|                      | Close Squelch Mode                 | Two Green flashes   |                  |
|                      | Save Squelch Mode                  | One Green flash     |                  |

## 5 Programming

The data modem is a pc programmable modem. The requirements include a pc (Windows 98 or later), programming cable (serial port or USB port cables available), the D200/D150 programmer and Programming Guide.

The parameters available for programming include:

- Frequency, channel spacing, power (5W or 1W), and sub-audible tones on a per channel basis.

- Standard radio settings such as power save mode, tx lockout, tx timeout can be programmed (not all available when an internal modem is fitted).

- Differing modem options can be programmed when the internal modem is fitted such as data settings (flow control, preamble delay etc.) and timings.

The pc program also allows for squelch adjustments and calibration.

## 6 Installation

### 6.1 Antennas

It is important that any antennas are installed in a suitable location with an adequate ground plane. Ideally, multiple antennas should be separated by a minimum of a wavelength (at the lowest frequency), whilst still retaining a good ground plane for each antenna. Therefore, for a 400MHz system, the ideal separation should be a minimum of 0.75m, and for 150MHz system the minimum should be 2.5m.

Warning: If installing an antenna near people it is necessary to ensure the minimum separation is maintained. This particularly important where prolonged exposure is likely.

### 6.2 Power sources

It is important that a “clean” source of power is used for the nominal 12V dc supply to the modem.

The power source must be capable of safely delivering 9-18V dc at up to 2 Amps. For added safety and protection of the modem it is recommended that an in-line or similar method of fuse is used in +ve line. The recommended safety fuse to be fitted is 250V T2A (Time Lag).

### 6.3 Cabling

If possible, run RF cables separately from other cables and keep RF cables apart from one another to avoid interference / coupling.

When fitting the modem into a fixed installation care must be taken in the routing of all cabling such that the insulation cannot become damaged.

## 6.4 Fixing

We recommend that the D150 is securely fixed to a surface, either directly, or with a suitable bracket. The fixing hole centre dimensions are as shown.

The modem can be attached to any surface by using suitable size screws through the M3 holes in the mounting flanges.

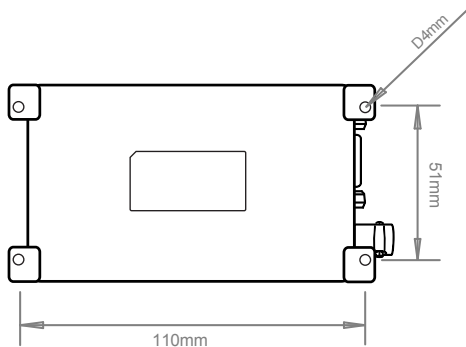

Note: We do not recommend that the D150 is fixed by cable ties to any wiring looms.

## **7 Safety and general information**

Important information on safe and efficient use of your Radio device

### **7.1 Exposure to radio frequency energy**

Your modem is a high power radio transceiver. When it is on, it receives and also sends out radio frequency (RF) signals. To help minimise human exposure to RF electromagnetic energy, keep transmission time to 50% or less.

As with all radio devices, holding the antenna affects transmission quality and may cause the radio to operate at a higher power level than required. Do not hold the antenna when the radio is in use.

Do not use radios with damaged or modified antenna, this may violate compliance with relevant international standards.

Where prolonged human exposure is likely, the minimum separation from the antenna should be 0.8m.

### **7.2 Electromagnetic interference/compatibility**

Most modern electronic equipment is shielded from RF energy. However certain electronic equipment may not be shielded against RF signals. The modem needs to be switched off in any facility where posted notices instruct you to do so to avoid electromagnetic interference or compatibility conflicts. Special care should be taken near facilities such as hospitals or health care centres may be using equipment that is sensitive to external RF energy.

### **7.3 Medical devices (Pacemakers)**

If you use any personal medical device, consult the manufacturer of your device to determine it is adequately shielded from RF energy. Your physician may be able to assist you in obtaining this information.

## **7.4 Vehicles with airbags**

Air bags inflate with great force. Do not place a radio in the area over an airbag or in the airbag deployment area, any radio may be propelled with great force and cause serious injury to the occupant of the vehicle.

## **7.5 Potentially explosive atmospheres**

Turn off your modem prior to entering any area with a potentially explosive atmosphere, unless it is a radio type especially qualified for use in such areas. Do not remove install or charge batteries in such areas. Sparks in potentially explosive atmospheres can cause an explosion or fire resulting in bodily injury or death.

Potentially explosive atmospheres include fuelling areas such as petrol stations, below decks on boats, fuel or chemical transfer or storage facilities, vehicles using liquid petroleum gas (such as propane or butane); areas where the air contains chemicals or particles such as grain, dust or metal powders, and any other area where you would normally be advised to turn off your vehicle engine. Areas with potentially explosive atmospheres are often but not always posted.

## **8 Warranty and repairs**

The D150 is a low maintenance device. Once installed it requires no ongoing maintenance.

In the event that your D150 modem needs repair, return your radio to an authorised supplier. Do not disassemble, modify or repair the unit unless the work is carried out by an approved supplier.

Incorrect assembly, modification or repair may cause irreparable damage to your unit and will invalidate any warranty.

## 9 Care of the equipment

Do not immerse the D150 modem in water or other fluids.

Do not use solvents or spirits for cleaning as this may cause damage to the case materials.

Do not over tighten connection to the modem.

## 10 Disposal / Recycling

The D150 is a Class 3 product in accordance with the Waste of Electrical and Electronic Equipment (WEEE) Directive. Disposal of this class of equipment must be carried out through an authorised recycling centre or contact your supplier.



Published by Mobile Expertise.

Any queries regarding information in this manual, please contact the Technical Services Group Leader at the above address.

Information provided in this document is believed correct at time of printing but is subject to change without notice.

Mobile Expertise will not accept liability for any loss, damage or costs howsoever caused as a result of the information provided.

Mobile Expertise Limited

Version 1.02

This user guide is published by Mobile Expertise Limited.

Improvements and changes to this user guide necessitated by typographical errors, inaccuracies of current information, or improvements to programs and/or equipment, may be made by mobile Expertise Limited at any time and without notice. Changes will be incorporated into new editions of this user guide.

© Mobile Expertise Limited, 2007.



[www.mobile-expertise.co.uk](http://www.mobile-expertise.co.uk)