

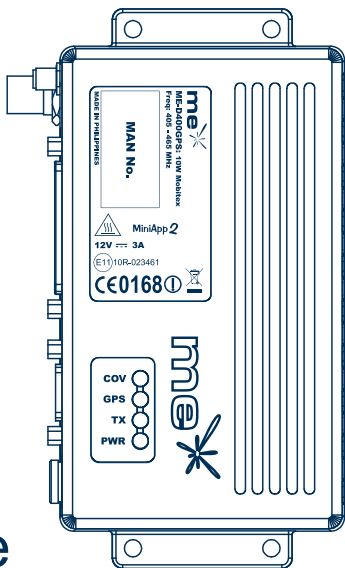

me-d400

me-d400gps



User Guide

Contents

Introduction.....	2
Preparing for use.....	3
Unpacking and inspection.....	3
Description of modem.....	4
MAN Numbers and MSN Number	5
Installation.....	5
Antennas.....	5
Power sources.....	6
Fusing.....	6
Fuse replacement.....	6
Cabling.....	7
Fixing.....	7
Connections.....	8
Start up & shut down.....	9
Introduction.....	9
Start up routine.....	9
Shut down routine.....	9
Safety and general information.....	10
Warranty and repairs.....	12
Care of the equipment.....	12
Disposal / Recycling.....	12
Declaration of conformity.....	13
Relevant specifications.....	14

Introduction

The me-d400 range is a 10 Watt Wide-band (405 to 465MHz) radio data modem for use on the 8kB/s Mobitex Networks.

The me-d400 offers, as standard, a serial data interface conforming to MASC standard together with PacketAT, which simplifies communication, and a telemetry interface which provides up to 12 configurable data lines.

The me-d400 is housed in a rugged cast-aluminium box sealed to IEC 529 (IP54) making it suitable for a wide range of mobile and fixed applications.

All me-d400 modem units meet the essential requirements of the relevant European directives. In order to maintain this compliance the installation and safety information must be adhered to at all times.

- The me-d400 modem must only be installed where unintentional contact cannot be made. The surface of the device may be hot to touch under certain transmit conditions. A warning label is permanently displayed as part of the equipment rating label affixed to the lid. The me-d400 is not designed for permanent transmission, it is a packet data system. When used for packet data, the me-d400 will operate just slightly warm under most conditions.
- When fitting the modem into a fixed installation, such as a vehicle for example, care must be taken in the routing of all cabling such that the insulation cannot become damaged.
- The inline "quick blow" fuse rating of 4 amps must not be exceeded at any time. See Fusing (under Installation) for further instructions
- The recommended supply sources for use with the me-d400 are a standard 12 volt vehicle battery but is capable of operating in the range (10.8V - 15.6V).

Preparing for use

Unpacking and inspection

Unpack the modem and check that you have received the following items:

- me-d400 mobitex modem
- User Guide (this document)
- DC cable (fused) CA8502

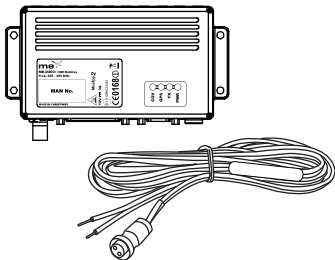

Or if you have purchased the me-d400gps version you should have received the following:

- me-d400gps mobitex modem
- User Guide (this document)
- DC cable (fused) CA8503

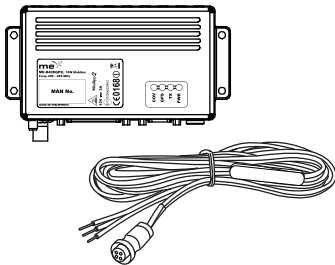

If any of these items are missing, please contact your supplier.

Description of modem

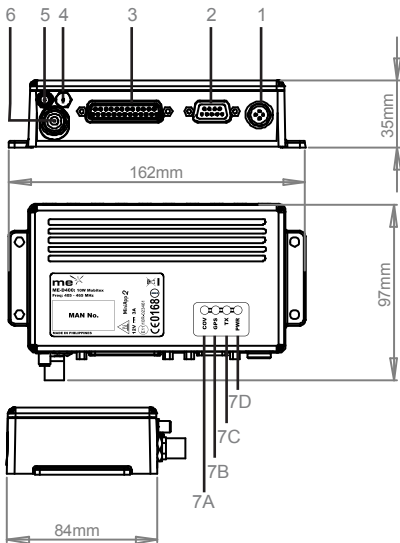

- 1 Power input (2 pin or 4 pin including ignition line depending on the model number)
- 2 RS232 control port (MASC, PacketAT): 9-way d-type
- 3 Telemetry/Serial TTL port (Masc, Debug, GPS): 25 way d-type
- 4 Aux
- 5 GPS antenna connector: SMA, if fitted
- 6 Mobitex antenna connector: TNC
- 7 LED's:
 - A) Orange – Mobitex coverage
 - B) Yellow – GPS coverage
 - C) Green – Transmitting / programming indicator
 - D) Red – power (power to unit and switched on)

The modem can be attached to any surface by using suitable size screws through the 5 mm holes in the mounting flanges.

MAN Numbers and MSN Number

The Mobitex Access Number (MAN) or subscription number is a unique number allocated to the radio modem when network connection is granted. The MAN number must be programmed into the modem by the supplier of the modem or the Network operator.

The Mobitex Security Number (MSN) is programmed into the modem during manufacture. It is unique to the modem and is registered by the Network Operator to confirm valid use of the network. Any attempt to alter this number will result in the permanent failure of the modem.

Installation

Antennas

It is important that any antennas are installed in a suitable location with an adequate ground plane. Ideally, multiple antennas should be separated by a minimum of a wavelength (at the lowest frequency), whilst still retaining a good ground plane for each antenna. Therefore, for a 400MHz system, the ideal separation should be a minimum of 0.75m. With the use of composite materials, especially on trucks, materials may have to be used to fabricate a suitable ground plane.

Warning: If installing an antenna on a vehicle roof for example, ensure a 0.8m separation to occupants is maintained. This is particularly important where prolonged exposure is likely, e.g. the driver

Power sources

It is important that a “clean” source of power is used for the 12V supply to the modem. Ideally, this is achieved by taking the supply directly from the battery terminals (or the fuseboard, if the battery is not accessible). Ensure that the cables from the battery to the power point are substantial to avoid voltage drops etc.

Note: The me-d400 power lead should have the red wire connected to +12V DC and the black wire connected to –ve (0V). Failure to wire the me-d400 correctly will cause damage and invalidate the warranty. Where a third ignition sense wire is required connect the brown (IGN) to the ignition line of the vehicle.

Frequently, either a large voltage glitch, or total loss of voltage may be observed on some vehicles at start-up. The loss of voltage to a me-d400 system can be avoided by the use of a small 12V lead acid battery and routing diode. See the Application Notes for further information.

It is recommended that star earthing, close to or at the battery, is used for all connections to the –ve terminal of equipment. This avoids the possibility of earth loops. These simple precautions ensure that the me-d400 continues to function under adverse conditions.

Important Note: The modem should have power applied to the circular power connector at all times. It should be turned on and off using DTR or the ignition line but not both. If there is a risk of power failure, then back-up supply is required to maintain the integrity of the Mobitex network (prevents the risk of lost messages).

Fusing

It is recommended that fuses for the me-d400, and any associated equipment, are located in a place away from the main fusebox. The inline “quick blow” fuse rating of 4 amps must not be exceeded at any time.

Fuse replacement

The fuse fitted is a F4A L250V. It is a 4 Amp fast blow glass fuse measuring 32mm x 6mm. Only replace with the same type fuse, e.g. Farnell Part No. 799-956.

Cabling

A variety of accessory cables are available which we recommend are used to interface to the me-d400. Please contact supplier for further details.

If possible, run RF cables separately from other cables and keep RF cables apart from one another to avoid interference / coupling.

When fitting the modem into a fixed installation, such as a vehicle for example, care must be taken in the routing of all cabling such that the insulation cannot become damaged.

Fixing

We recommend that the me-d400 is securely fixed to a surface, either directly, or with a suitable bracket. The fixing hole centre dimensions are as shown.

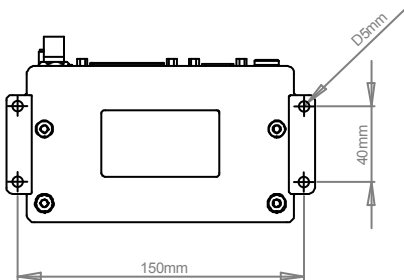

Note: We do not recommend that the me-d400 is fixed by cable ties to any wiring looms.

Connections

There are two types of power connection available, normally depending on whether GPS is fitted or not. The 2 pin circular connector is for connection to the power supply only, when no GPS is fitted, whereas the 4 pin circular connector includes an ignition line. This ignition line can be used to power up the modem, or alternatively the modem can be powered up by asserting the DTR (Data Terminal Ready) line (see application notes).

The Mobitex antenna connector is a TNC female and the GPS antenna connector, if fitted, is an SMA female

The me-d400 has a standard 9 way D-Type RS232 port, the MASC control port, which includes the DTR pin (see application notes).

The standard 25 way D-Type socket is the TTL interface representation of the RS232 connector. It is the telemetry serial port which outputs the GPS, MASC, Debug and programmable input/output lines. Please refer to the Application Notes for further information. If standard RS232 signal levels are required on the D25 socket, a separate accessory lead is available to provide the necessary signal inversion from TTL level to true RS232.

The MiniApp pin source current is 0.4mA when the output is high and 1.4mA when the output is low. RS232 level signals are +4.5v to +12v for an asserted signal and -4.5v to -12v for a de-asserted signal. Pins 2 to 8, 20 and 22 are standard RS232 pin connections. Pin 1 is +5V and not ground as per RS232.

Note: Incorrect connection may damage the modem and will invalidate the warranty.

It is recommended that any unused pins are pulled to their de-asserted level with a 47K resistor. This is particularly important if the MASC Port is not used, to avoid any unnecessary interrupts caused by floating pins slowing down the modem. The MiniApp lines are polled, but allowing them to float causes extra messages to be sent, which if configured, can cause lines to be blocked awaiting replies. Refer to the Application Notes.

Note: The me-d400 Application Notes, and free demonstration software, are available from the Mobile Expertise Web Site, www.mobile-expertise.co.uk.

Start up and shutdown

Introduction

The me-d400 operates on the Mobitex networks using Mobitex Asynchronous Control Protocol (MASC Protocol). The me-d400 modem is preconfigured for use with MASC as shipped from Mobile Expertise. Therefore, if only MASC is required, the modem is ready for use immediately.

If additional features, such as input/output lines are to be used, the modem will need to be configured. Please refer to the Application Notes. This may also include PacketAT, which is a simple protocol which “sits on top of” MASC and provides communication between modems. PacketAT is described in the Application Notes.

Start up routine

Please refer to the Application Notes.

Important Note: The modem should have power applied to the connector at all times, but it is powered up by using either the ignition line or the DTR command (RS232 port or TTL port). Once power has been applied to the mode, the modem will begin its power up procedure after a 240mS delay.

The modem will start with all pins of the D25 at a ground state with the exception of the DTR pin, which has an internal bias resistor to bias this high. The DTR pin should be taken to ground as a clean edge during a clean power supply condition.

Shut down routine

The modem should never be powered down by interrupting the power as this will leave the modem as active non contactable on the network, and stop the modem saving important information at power down. The modem should always be correctly shutdown, using commands as detailed in the application notes. The method depends on whether Miniapp is configured or the MASC port is used, or both.

Safety and general information

Important information on safe and efficient use of your Radio device

Exposure to radio frequency energy

Your modem is a high power radio transceiver. When it is on, it receives and also sends out radio frequency (RF) signals. To help minimise human exposure to RF electromagnetic energy, keep transmission time to 50% or less.

As with all radio devices, holding the antenna affects transmission quality and may cause the radio to operate at a higher power level than required. Do not hold the antenna when the radio is in use.

Do not use radios with damaged or modified antenna, this may violate compliance with relevant international standards.

Where prolonged human exposure is likely, the minimum separation from the antenna should be 0.8m.

Electromagnetic interference/compatibility

Most modern electronic equipment is shielded from RF energy. However certain electronic equipment may not be shielded against RF signals.

The modem needs to be switched off in any facility where posted notices instruct you to do so to avoid electromagnetic interference or compatibility conflicts. Special care should be taken near facilities such as hospitals or health care centres which may be using equipment that is sensitive to external RF energy.

Medical devices (Pacemakers)

If you use any personal medical device, consult the manufacturer of your device to determine it is adequately shielded from RF energy. Your physician may be able to assist you in obtaining this information.

Vehicles with airbags

Air bags inflate with great force. Do not place a radio in the area over an airbag or in the airbag deployment area, any radio may be propelled with great force and cause serious injury to the occupant of the vehicle.

Potentially explosive atmospheres

Turn off your modem prior to entering any area with a potentially explosive atmosphere, unless it is a radio type especially qualified for use in such areas. Do not remove install or charge batteries in such areas. Sparks in potentially explosive atmospheres can cause an explosion or fire resulting in bodily injury or death.

Potentially explosive atmospheres include fuelling areas such as petrol stations, below decks on boats, fuel or chemical transfer or storage facilities, vehicles using liquid petroleum gas (such as propane or butane); areas where the air contains chemicals or particles such as grain, dust or metal powders, and any other area where you would normally be advised to turn off your vehicle engine. Areas with potentially explosive atmospheres are often but not always posted.

Warranty and repairs

The me-d400 is a low maintenance device. Once installed it requires no ongoing maintenance.

In the event that your Mobile Expertise d400 modem needs repair, return your radio to an authorised Mobile Expertise supplier. Do not disassemble, modify or repair the unit unless the work is carried out by a Mobile Expertise approved supplier. Incorrect assembly, modification or repair may cause irreparable damage to your unit and will invalidate any warranty.

Care of the equipment

- Do not immerse the d400 modem in water or other fluids.
- Do not use solvents or spirits for cleaning as this may cause damage to the case materials.
- Do not over tighten connection to the modem.

Disposal / Recycling

The me-d400 is a Class 3 product in accordance with the Waste of Electrical and Electronic Equipment (WEEE) Directive. Disposal of this class of equipment must be carried out through an authorised recycling centre or contact your supplier.



Declaration of conformity*

The me-d400 range is a 10 Watt Wide-band (405 to 465MHz radio data modem for use on the 8kB/s Mobitex Networks. The me-d400 also comes with an optional internal GPS module and is designated me-d400gps. This is a licenced service, restriction of use may apply in some countries.

This equipment is intended for use in:-

Austria, Belgium, Czech Republic, Cyprus, Denmark, Estonia, Finland, France, Germany, Greece, Hungary, Ireland, Italy, Latvia, Lithuania, Luxembourg, Malta, The Netherlands, Poland, Portugal, Slovakia, Slovenia, Spain, Sweden, Switzerland, United Kingdom, Iceland, Liechtenstein, Norway, Bulgaria, Romania & Turkey.

This equipment can also be used worldwide, where a relevant Mobitex network is available and where the equipment is approved for use.

We hereby declare that the above named product is in conformity to all the relevant essential requirements of Directive 1999/5/EC.

Wir möchten hiermit bekanntgeben, daß das oben genannte Produkt in Übereinstimmung mit allen erforderlichen Bedürfnissen der 1999/5/EC Direktive steht

Certificamos que el aparato es conforme con lo establecido en las disposiciones de la Directiva 1999/5/CE.

Nous déclarons que le produit référencé ci-dessus satisfait aux exigences R&TTE 1999/5/EC qui lui sont applicables.

Relevant Specifications

This is a Class II product in accordance with the R&TTE Directive, 1999/5/EC.

CE0168!

*A signed and dated Declaration of Conformity is available on request.

Note: This document and others relating to the me-d400 are available from the Mobile Expertise Web Site, www.mobile-expertise.co.uk.

Published by Mobile Expertise Limited.

Any queries regarding information in this manual, please contact the Technical Services Group Leader at the above address.

Information provided in this document is believed correct at time of printing but is subject to change without notice.

Mobile Expertise Limited will not accept liability for any loss, damage or costs howsoever caused as a result of the information provided.

Mobile Expertise Limited

Version 1.3

This user guide is published by Mobile Expertise Limited. Improvements and changes to this user guide necessitated by typographical errors, inaccuracies of current information, or improvements to programs and/or equipment, may be made by Mobile Expertise Limited at any time and without notice. Changes will be incorporated into new editions of this user guide.

© Mobile Expertise Limited, 2007.

www.mobile-expertise.co.uk